

LDO Voltage Regulator 250 mA TSMC N3P

SILVACO

LDO Voltage Regulator, 250 mA, Adjustable 0.45 V to 0.9 V Output

The LDO IP is a 1.2V low-quiescent-current adjustable output voltage Low-Drop-Out (LDO) Linear Regulator implemented in the TSMC 3nm N3P CMOS process technology. Its low sleep current, 250 mA maximum current, output voltage adjustability and precision make it especially suitable for use as an integrated voltage regulation source for subsystems implemented in analog, digital, mixed-signal and RF ASICs and SoCs.

Features

- TSMC 3nm FinFET process
- Input voltage: 1.2 V
- Output voltage range: 0.45 V to 0.9 V
- Vout adjustable in 50 mV increments
- Load current: 250 mA (max)
- PSRR:
 - o 36 dB @ < 1 KHz
 - o 12 dB @ > 10 MHz
- < 50 mV undershoot/overshoot for load transients 1 A/ns
- Compact area
- Capless stable operation
- Functional from -40°C to 125°C

Deliverables

- SPICE netlist
- GDSII
- Behavioral Model
- IP Datasheet
- User's Guide

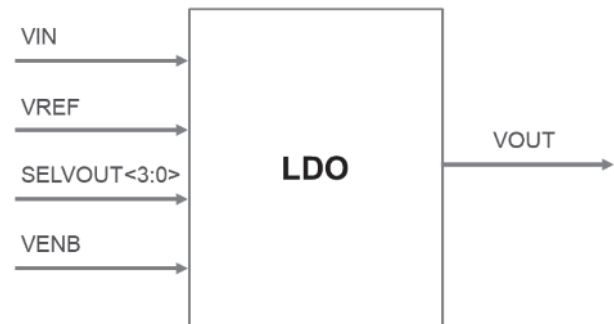

Specifications

Silvaco LDO	Values			
	Minimum	Typical	Maximum	Units
Core Supply Voltage	1.08	1.2	1.32	V
Input Reference Current				uA
Output Current Capability			250	mA
Quiescent Current Consumption				uA
Sleep-Mode Consumption				uA
PSRR (1 KHz)		36		dB
PSRR (10 MHz)		12		dB
Output Noise (10MHz)				nv/rtHz
Silicon Area				mm ²